

The aluminum ring casting of overall size 682 mm x 600 mm x 115 mm weighs 9.7 kg, and has relatively high shape complexity. It was observed to have shrinkage porosity along the junction of ribs resulting in high rejection rate.

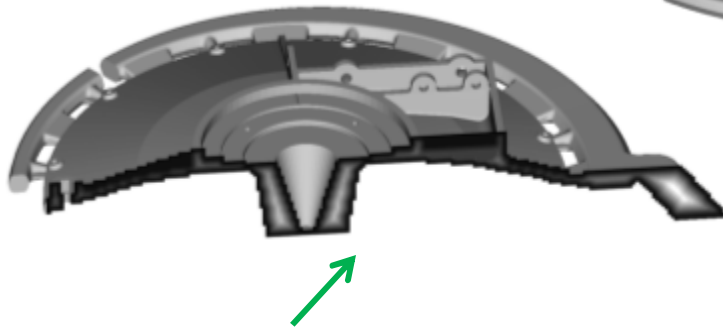

Part and thickness analysis shows multiple ribs connected to each other creating T-junctions.

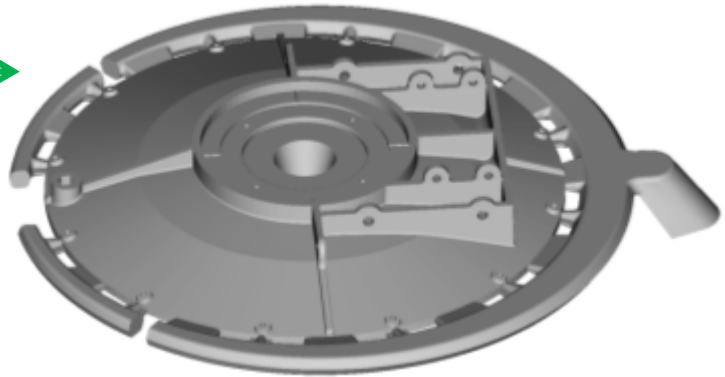
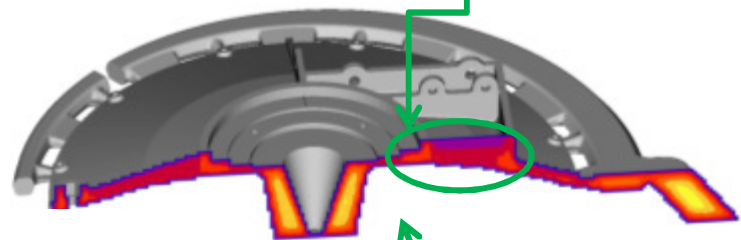

The solidification simulation indicates lack of directional feeding of the junction ribs from the side feeder, resulting in shrinkage porosity matching the defect in original casting.

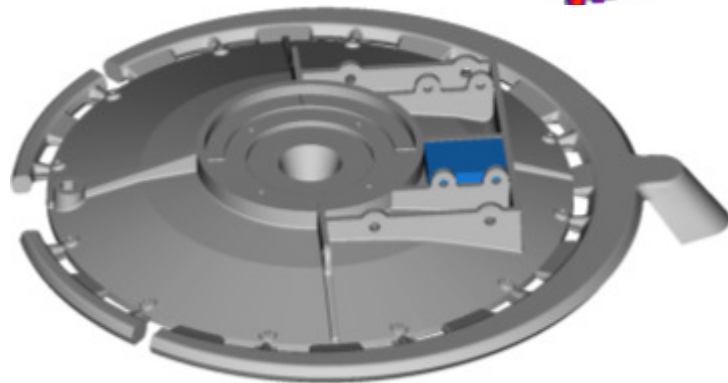

Since the part is relatively thin, it is not possible to feed the defect-prone area. An alternative solution is to reduce the hot spot region by placing chills of dimension 50 x 75 x 25 mm. This improves the directional solidification and eliminates the shrinkage defect.

